

Instruction Manual

PicoDRY *Ultra Compact High Vacuum Pumping Unit*

<i>Description</i>	<i>Flange</i>	<i>Voltage</i>	<i>Item Number</i>
<i>PicoDRY</i>	<i>NW40</i>	<i>220 V 50/60 Hz</i>	<i>TA1A-02-021</i>
<i>PicoDRY</i>	<i>NW40</i>	<i>110 V 50/60 Hz</i>	<i>TA1A-02-022</i>
<i>PicoDRY</i>	<i>NW40</i>	<i>100 V 50/60 Hz</i>	<i>TA1A-02-023</i>
<i>PicoDRY with AGC</i>	<i>NW40</i>	<i>220 V 50/60 Hz</i>	<i>TA1A-12-021</i>
<i>PicoDRY with AGC</i>	<i>NW40</i>	<i>110 V 50/60 Hz</i>	<i>TA1A-12-022</i>
<i>PicoDRY with AGC</i>	<i>NW40</i>	<i>100 V 50/60 Hz</i>	<i>TA1A-12-023</i>

Note:

Other variants include CF63 or ISO63 inlet flange, auto vent option and a gauge controller which can be a three-head, single-display version or a six-head, triple-display version. Refer to Section 2 for full list of Item Numbers.



Declaration of Conformity

We, BOC Edwards,
Manor Royal,
Crawley,
West Sussex RH10 2LW, UK

declare under our sole responsibility that the product(s)

PICODRY configured using the following matrix structure:

T A x A - x 2 - 0 x x

Flange:

- 1. DN40KF
- 3. DN63ISO-K
- 4. DN63CF-F

Gauging:

- 0. None
- 1. AGC, single digital display,
3 gauge heads, RS232 port
- 5. AGC, triple digital display,
6 gauge heads, RS232 port

Nominal Electrical supply:

- 1. 230 V, 50 Hz (Europe)
- 2. 115 V, 60 Hz (USA)
- 3. 100 V, 50/60 Hz (Japan)

Turbomolecular pump accessories:

- 2. ACX Air Cooler
- 4. ACX Air Cooler and
TAV5 Vent Valve

to which this declaration relates is in conformity with the following standard(s)
or other normative document(s)

EN 1012-2	Safety Requirements for Compressors and Vacuum Pumps.
EN61010-1	Safety Requirements for Electrical Equipment for Measurement, Control and Laboratory Use.
EN61326 (Class B Emissions)	Electrical Equipment for Measurement, Control and Laboratory Use - EMC Requirements.

following the provisions of

98 / 37 / EC	Machinery Safety Directive.
73 / 023 / EEC	Low Voltage Directive.
89 / 336 / EEC	Electromagnetic Compatibility Directive.



Dr. J.D. Watson, Senior Technical Manager, VED

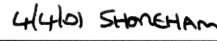

Date and Place

This product has been manufactured under a quality system registered to ISO9001

CONTENTS

Section	Title	Page
1	INTRODUCTION	1
1.1	Scope and definitions	1
1.2	Description	2
1.3	Main components of the PicoDRY unit	2
1.4	Principles of operation	2
1.5	Remote control facility	4
1.6	Options	4
1.6.1	Auto vent valve	4
1.6.2	Active Gauge Controller (AGC) option	4
2	TECHNICAL DATA	7
2.1	Pumping media	7
2.2	Mechanical data	7
2.3	Electrical data	7
2.4	Performance	8
2.5	Remote control signals	8
2.6	AGC option interface data	8
2.7	Item Numbers	8
3	INSTALLATION	10
3.1	Safety	10
3.2	Unpack and inspect	10
3.3	System identification	10
3.4	Install the PicoDRY pumping unit	10
3.5	Electrical installation	11
3.6	Complete the installation	11
3.6.1	Local control connections	11
3.6.2	Remote control connections	12
3.6.3	Active gauge interface connections	12
4	OPERATION	13
4.1	General	13
4.2	Operation using remote control	13
4.3	Operation using the gauge interface	14
5	MAINTENANCE	15
5.1	Safety information	15
5.2	Diaphragm pump	15
5.2.1	Servicing	15
5.2.2	Fault-finding	16
5.2.3	Spare parts and order numbers	18
5.3	AGC option (if fitted)	18

Section	Title	Page
6	STORAGE AND DISPOSAL	20
6.1	Storage	20
6.2	Disposal	20
7	SERVICE, SPARES AND ACCESSORIES	21
7.1	Introduction	21
7.2	Service	21
7.3	Spares	21
7.4	Accessories	21
8	ENGINEERING DIAGRAMS	22
	RETURN OF BOC EDWARDS EQUIPMENT	

Illustrations

Figure	Title	Page
1	Main components of the PicoDRY unit	3
2	PicoDRY backplate details	5
3	AGC option fitted to PicoDRY pump unit	5
4	Rear panel of AGC option	6
5	Components of the diaphragm pump	19
6	Circuit diagram	23

Tables

Table	Title	Page
1	Product item numbers	9
2	Electrical supply cable connections	11
3	Remote control cable connections	12
4	Fault finding	17
5	Spare parts	18

Associated publications

Publication title	Publication number
EXT70H and EXT250H/Hi Compound Molecular Pumps	B722-21-880
EXC100E and EXC100L Turbomolecular Pump Controllers	D396-20-880
AGC Active Gauge Controller	D386-55-880

1 INTRODUCTION

1.1 Scope and definitions

This manual provides installation, operation and maintenance instructions for the BOC Edwards PicoDRY High Vacuum Pumping Unit. Read this manual before you attempt to install and operate the unit.

This manual contains essential safety information which supplements the safety features of the unit. Safety procedures are highlighted as WARNING and CAUTION instructions. You must obey these instructions. The use of WARNINGS and CAUTIONS is defined below.

WARNING

Warnings are given when failure to observe the instruction could result in injury or death to people.

CAUTION

Cautions are given where failure to observe the instruction could result in damage to the equipment, associated equipment or process.

The units used throughout this manual conform to the SI international system of units of measurement.

1.2 Description

The PicoDRY High Vacuum Pumping Unit consists of a compound turbomolecular pump backed by a twin-head diaphragm vacuum pump.

The operation of the turbo pump is controlled by an EXC100L controller. An integral active gauge controller (AGC) is available as an option.

The unit comprises the items listed in Section 1.3.

1.3 Main components of the PicoDRY unit

The PicoDRY unit comprises the following main components:

- EXT70H compound turbomolecular pump.
- Twin-head diaphragm vacuum pump.
- EXC100L turbo controller.
- Purpose built enclosure.
- Integral AGC option.

1.4 Principles of operation

The internal components of the PicoDRY unit are shown in Figure 1.

Refer to Figure 1 for items in brackets in the following sections.

The PicoDRY unit has an EXT70H compound turbomolecular pump (2) which is backed by a Twin-head diaphragm pump (1). The turbomolecular pump is controlled by an EXC100L controller (Figure 3, item 3).

The operation of the unit is fully automatic; the only operator control being the ON/OFF switch (7). The unit is fan cooled through a louvered air-vent (4) at the front of the enclosure. The turbomolecular pump status display consists of three lamps (8) with the following functions:

- RUNNING lamp (green) indicates that power is available and the turbomolecular pump is switched on.
- NORMAL SPEED lamp (green) indicates that the turbomolecular pump has reached normal operating speed (>80%).
- FAIL lamp (red) indicates that the turbomolecular pump has failed which will typically be due to excessive pumping load.

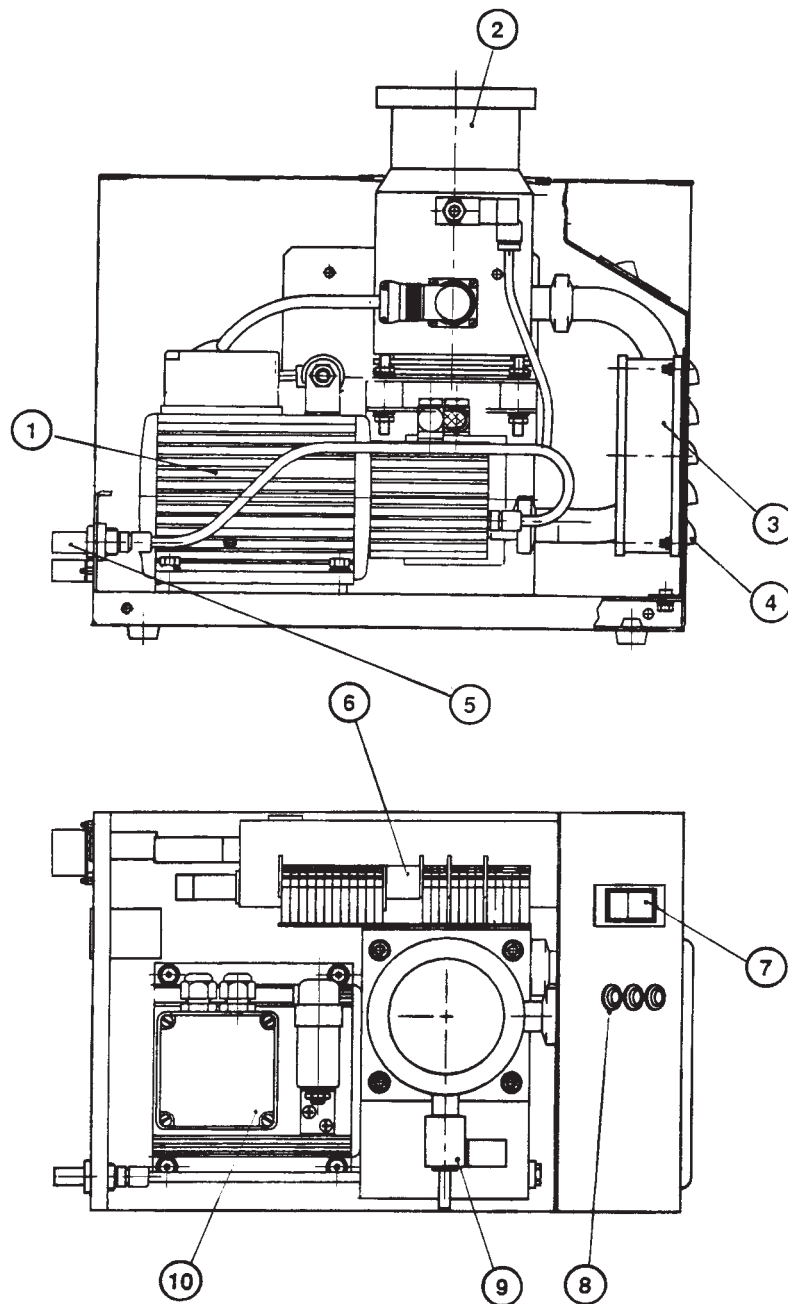

- | | |
|--------------------------------|--------------------------------------|
| 1. Diaphragm pump | 6. Terminal block |
| 2. Compound turbo pump EXT 70H | 7. Pump ON/OFF switch |
| 3. Cooling fan | 8. Turbo status LEDs |
| 4. Air vent | 9. Solenoid operated vent valve TAV5 |
| 5. Exhaust silencer | 10. Electrical terminal box |

Figure 1 - Main components of the PicoDRY unit

1.5 Remote control facility

A logic interface 'D' type socket (Figure 2, item 4) and mating plug is provided on the unit to enable remote control of start/stop and standby operation of the turbomolecular pump. If local control is required, the mating plug with the link as supplied must be fitted. When the remote function is required, a link must first be removed from the plug and the remote cable connected to the appropriate pins of the plug (see Section 3).

The turbomolecular pump can also be controlled by an Active Gauge Controller, or interlocked by an Active Pirani Gauge, through the Active gauge connector (Figure 2, item 5). In this case the mating plug must be removed or the link in the plug must be cut (see Section 3).

1.6 Options

1.6.1 Auto vent valve

A solenoid operated vent valve controlled by the EXC100L Turbocontroller opens automatically when the turbomolecular pump shuts down for any reason. The vent valve is held closed until the turbomolecular pump has decelerated to 50% of normal rotational speed to prevent undue load on the pump.

1.6.2 Active Gauge Controller (AGC) option

The AGC option is enclosed in a subframe assembly which is fitted under the main unit (see Figure 3). This option is supplied as a prewired, factory assembled unit.

Two AGC options are available:

- AGC single display, three-head, with RS232
- AGC triple display, six-head, with RS232

The Active Gauge heads and cables are not supplied with the PicoDRY unit and must be purchased separately.

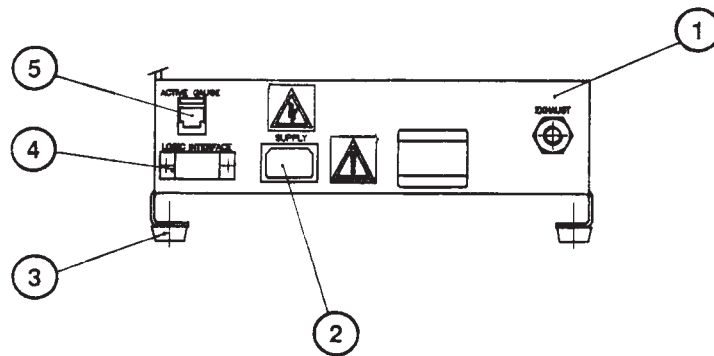

- | | |
|--|------------------------------|
| 1. Backplate
(refer to Figure 4 for AGC rear panel) | 3. Rubber foot (4 off) |
| 2. Electrical supply IEC socket | 4. Logic interface connector |
| | 5. Active gauge connector |

Figure 2 - PicoDRY backplate details

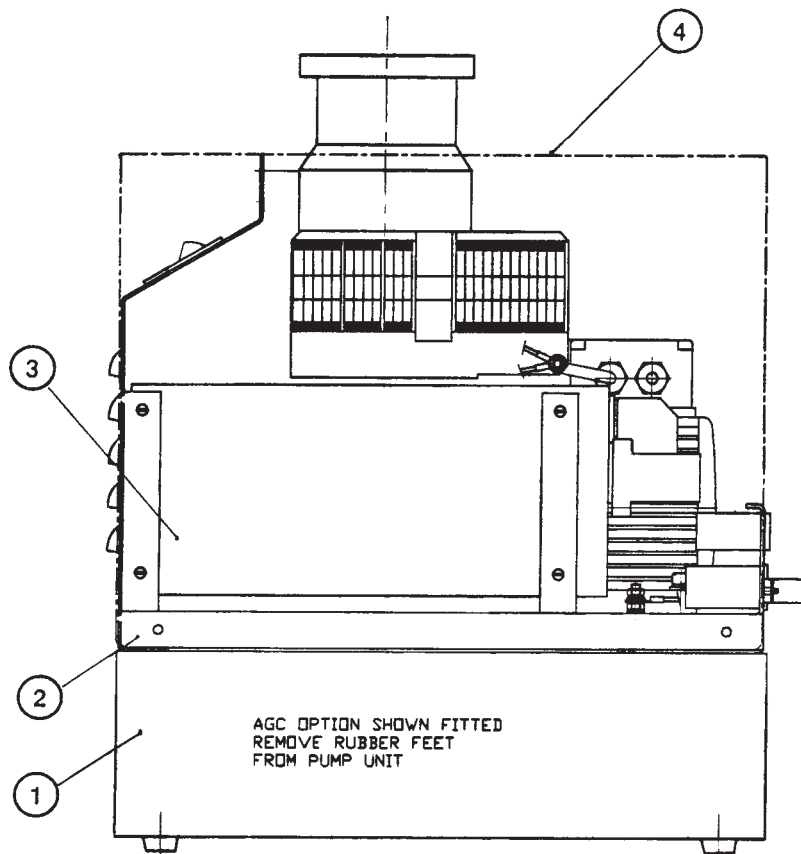

- | | |
|-------------------------|--------------------------------|
| 1. AGC option enclosure | 3. EXC100L turbo controller |
| 2. Pump unit baseplate | 4. Case outline (shown dotted) |

Figure 3 - AGC option fitted to PicoDRY pump unit

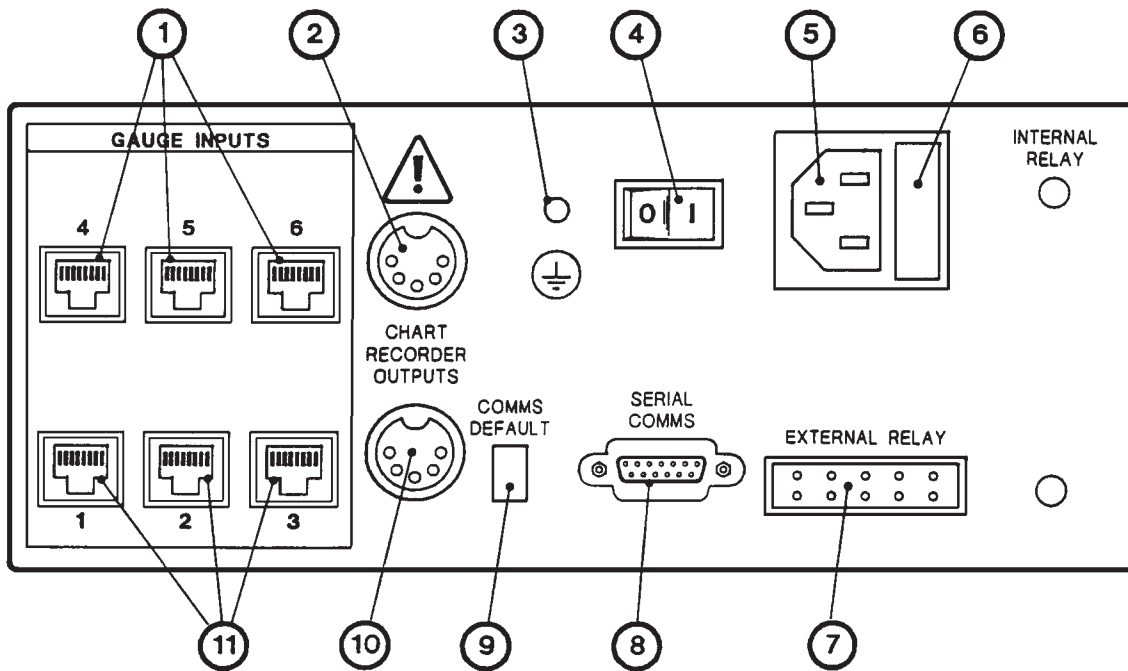

- | | |
|-------------------------------------|-------------------------------------|
| 1. Active gauge sockets 4, 5 and 6* | 7. External relay connector |
| 2. Chart recorder socket 2* | 8. RS232 connector |
| 3. Earth (ground) stud | 9. Communications default switch |
| 4. On/off switch | 10. Chart recorder socket 1 |
| 5. Electrical supply connector | 11. Active gauge sockets 1, 2 and 3 |
| 6. Fuse holder | |

* Six head AGCs only

Figure 4 - Rear panel of AGC option

2 TECHNICAL DATA

WARNING

The PicoDRY is not designed to pump dangerous gases.

2.1 Operating and storage data

Ambient operating temperature	5 °C to 35 °C
Ambient storage temperature	-30 °C to +70 °C
Maximum operating humidity	80% RH (at maximum operating temperature)

2.2 Pumping media

Refer to Section 2 of the associated publication B722-21-880.

2.3 Mechanical data

Dimensions (overall H x W x D)	330 x 245 x 355
Mass (unit)	19 kg (21 kg for CF version)
(unit with AGC option)	22 kg (24 kg for CF version)
Inlet vacuum connection options	DN40NW, DN63ISO, DN63CF
Exhaust connection	1/8 inch BSP

2.4 Electrical data

Electrical supply options	230 V 50 Hz, 115 V 50/60 Hz or 100 V 50/60 Hz
Maximum input power	320 VA
Fuse rating (plug)	3 A
Electrical connectors	
Electrical supply connector socket type	IEE/IEC 320
Active gauge connector	FCC68, 8-way
Logic interface connector	15-way sub-miniature 'D' type socket

2.5 Performance

Diaphragm pump pumping speed (N ₂)	13 lmin ⁻¹
Turbomolecular pump pumping speed (N ₂)	65 ls ⁻¹
Ultimate vacuum	<5 x 10 ⁻⁸ mbar

2.6 Remote control signals

(Remote link between pins 3 and 4 of the remote control plug)

Remote start	Pins 3 and 4 closed
Remote stop	Pins 3 and 4 open
Remote standby	Pins 11 and 4 closed
Analogue output	0 to +10 V d.c. (proportional to pump motor speed)
Refer to the associated instruction manual for more details	D396-20-880

2.7 AGC option interface data

Refer to associated instruction manuals	D386-55-880
	D386-52-880

2.8 Item Numbers

Refer to Table 1 for a full list of the available product Item Numbers.

Inlet flange	Gauge Controller		Vent options		Item number		
	3 head	6 head	No vent	Auto vent	220-240 V	110 V	100 V
DN40NW			✓		TA1A02021	TA1A02022	TA1A02023
DN40NW	✓		✓		TA1A12021	TA1A12022	TA1A12023
DN40NW		✓	✓		TA1A52021	TA1A52022	TA1A52023
DN40NW				✓	TA1A02041	TA1A02042	TA1A02043
DN40NW	✓			✓	TA1A12041	TA1A12042	TA1A12043
DN40NW		✓		✓	TA1A52041	TA1A52042	TA1A52043
DN63ISO			✓		TA3A02021	TA3A02022	TA3A02023
DN63ISO	✓		✓		TA3A12021	TA3A12022	TA3A12023
DN63ISO		✓	✓		TA3A52021	TA3A52022	TA3A52023
DN63ISO				✓	TA3A02041	TA3A02042	TA3A02043
DN63ISO	✓			✓	TA3A12041	TA3A12042	TA3A12043
DN63ISO		✓		✓	TA3A52041	TA3A52042	TA3A52043
DN63CF			✓		TA4A02021	TA4A02022	TA4A02023
DN63CF	✓		✓		TA4A12021	TA4A12022	TA4A12023
DN63CF		✓	✓		TA4A52021	TA4A52022	TA4A52023
DN63CF				✓	TA4A02041	TA4A02042	TA4A02043
DN63CF	✓			✓	TA4A12041	TA4A12042	TA4A12043
DN63CF		✓		✓	TA4A52041	TA4A52042	TA4A52043

Table 1 - Product item numbers

3 INSTALLATION

3.1 Safety

WARNING

Obey the safety instructions given below and take note of appropriate precautions. If you do not, you can cause injury to people and damage to equipment.

- A suitably trained and supervised technician must install the unit.
- Do not use the PicoDRY to pump dangerous gases.

3.2 Unpack and inspect

Remove all packing materials and protective covers and check the unit for damage. If the unit is damaged, notify your supplier and the carrier in writing within three days; state the Item Number of the unit together with your order number and your supplier's invoice number. Refer to Section 3.3 for system identification.

Retain all packing materials for inspection. Do not use the unit if it is damaged.

If the unit is not to be used immediately, replace the protective covers. Store the unit in suitable conditions, as described in Section 6.1.

3.3 System identification

The system identification label is fixed to the unit. Please quote the model number, serial number and order number in all communications regarding this equipment.

3.4 Install the PicoDRY pumping unit

1. Provide a firm, level surface for the unit.
2. Use a suitable vacuum connector and seal to connect your process system to the inlet flange at the top of the pumping unit.
3. Connect the pump exhaust to your exhaust extraction system (if available). If necessary, remove the exhaust silencer (Figure 1, item 5).

3.5 Electrical installation

WARNING

Ensure that the electrical installation of the unit conforms with your local and national safety requirements. It must be connected to a suitably fused and protected electrical supply and a suitable earth point.

Check that your electrical supply is suitable for the unit (refer to Section 2 for data). An electrical supply cable is supplied with the unit which has an IEC type connector at one end and is unterminated at the other.

Insert the IEC plug on the cable into the socket on the backplate (Figure 2, item 2) of the unit, then connect the wires at the free end of the cable to your electrical supply, as shown in Table 2.

Wire colour	Electrical supply connection
Brown	Live (line)
Blue	Neutral
Green/yellow	Earth (ground)

Table 2 - Electrical supply cable connections

3.6 Complete the installation

Refer to Figure 2.

3.6.1 Local control connections

If you do not wish to use remote control operation or interlocked operation using the Active gauge interface, ensure that the 'D' type plug with factory fitted wire link (pin 3 to pin 4) is fitted into the logic interface connector (4).

3.6.2 Remote control connections

If you wish to connect the unit for remote control operation, proceed as follows:

1. Remove the 'D' type plug from the socket (4) labelled LOGIC INTERFACE.
2. Disconnect the wire link between pins 3 and 4 of the plug.
3. Connect the wires in your remote control cable to the pins in the plug as detailed in Table 3. A voltage-free contact closure between pin 3 and common pin 4 is required to start or stop the unit. A voltage-free contact closure between pin 11 and common pin 4 is required to select standby operation.

Remote function	Remote plug pin
Start/stop	3
Standby	11
Common	4
Analogue output (0 to 10 V)	2
	9

Table 3 - Remote control cable connections

3.6.3 Active gauge interface connections

If you wish to link the turbomolecular pump controller of the unit to the AGC to allow the AGC to control and display the status of the turbomolecular pump then proceed as follows:

1. Remove the 'D' type plug from the socket labelled LOGIC INTERFACE.
2. Connect the Active gauge interface to any of the gauge inputs on the AGC using an Active gauge cable.

If you wish to use an Active Pirani Gauge (APG) or Active Thermocouple Gauge (ATC) directly to interlock the starting of the turbomolecular pump then proceed as follows:

1. Remove the 'D' type plug from the socket labelled LOGIC INTERFACE.
2. Connect the Active gauge interface to an APG or ATC using an Active gauge cable.

4 OPERATION

4.1 General

WARNING

If the ON/OFF switch is left on after an electrical failure, the unit will automatically restart when the electrical supply is restored. Ensure that people cannot be injured by the rotating blades of the turbomolecular pump.

CAUTION

If the automatic vent valve is fitted, the unit will automatically vent the vacuum system when the unit is switched off or if the unit is shut down by the protection circuit.

CAUTION

Do not move the PicoDRY while it is running.

Operation consists of simply operating the ON/OFF switch on the unit or alternatively controlling the unit remotely via the remote control connector or Active gauge interface.

The RUNNING lamp will indicate that the turbomolecular pump is running and the NORMAL lamp will indicate when the turbomolecular pump has reached normal running speed (that is, a speed >80% approximately).

If the unit is subjected to an excessive pumping load, the automatic protection circuit will operate to shut down the unit and the FAIL lamp will light on the turbomolecular pump status panel. To restart the turbomolecular pump the unit must be switched off and then on again.

If the optional automatic vent valve is fitted, the unit will automatically vent the vacuum system whenever the unit is switched off or if the unit is shut down by the protection circuit. The vent valve is held closed until the turbomolecular pump has decelerated to 50% of its normal rotational speed.

4.2 Operation using remote control

If the remote control option is used, operating the ON/OFF switch will only switch on the diaphragm pump. The turbomolecular pump will only be switched on when the start/stop pin on the remote connection is connected to the common pin.

Note that when the auto vent option is fitted to the PicoDRY, the vent valve is only closed when the turbomolecular pump is switched on. This means that when using remote control, the diaphragm pump will be pumping with the vent valve open until the turbomolecular pump is switched on.

4.3 Operation using the gauge interface

For details of operation with the Active Gauge Controller (AGC) linked to the PicoDRY, refer to the TURBO CONTROL section of the AGC working instructions. The PicoDRY will appear to the AGC as an EXC100 turbomolecular pump controller.

An Active Pirani Gauge (APG) or Active Thermocouple Gauge (ATC) connected to the gauge interface allows the gauge head setpoint output to control the switching on and off of the turbomolecular pump in exactly the same way as the remote control start/stop (refer to Section 4.2). Refer to the gauge head working instructions for details of how to adjust the gauge head setpoint.

5 MAINTENANCE

5.1 Safety information

WARNING

Obey the safety instructions given below and take note of appropriate precautions. If you do not, you can cause injury to people and damage to equipment.

- A suitably trained and supervised technician must maintain the PicoDRY.
- Allow the PicoDRY to cool to a safe temperature before you start maintenance work.
- Isolate the PicoDRY and other components in the pumping system from the electrical supply so that they can not be operated accidentally.
- Do not reuse 'O' rings and Co-Seals.
- Take care to protect sealing-faces from damage.

5.2 Diaphragm pump

5.2.1 Servicing

The diaphragm and valve plates are the only parts of the pump subject to wear. Always change the diaphragm, valve plates and sealing rings at the same time.

To change the diaphragm, valve plates and sealing rings you will require the following spare parts and tools:

- Spare parts (refer to Table 5 - The spare parts list):
 - Structured diaphragm (1 off)
 - Valve plates (2 off)
 - Sealing rings (2 off)
- Ring spanner 14 mm (or open-ended spanner 14mm)
- Philips-head screwdriver No. 1
- Felt pen

When you change the diaphragm and valve plates, inspect all the parts of the pump head for dirt before you re-assemble it and clean them if necessary. If a compressed air line is available, use it to blow the parts.

Change the diaphragm, valve plates and sealing rings in the following sequence:

1. Remove the head connection.
2. Remove the cover plate from the housing.
3. Remove the pump head.

5.2.2 Fault finding

To identify the fault, refer to Table 4 and check the pump in the order given in the table.

If the pump does not operate correctly and you cannot find any of the faults given in the table, contact the BOC Edwards Service Centre for advice.

If you return the pump to BOC Edwards, please include information about the media that it has handled. If your pump has been handling dangerous gases, please clean the pump before you dispatch it.

Symptom	Check	Action
Pump produces no flow.	Has the thermal switch opened due to overheating ?	Disconnect the pump from the electrical supply and allow it to cool. Trace the cause of the overheating and eliminate it.
	Are the connections or pipelines blocked ?	Remove the blockage.
	Is an external valve closed or a filter blocked ?	Remove the blockage.
	Has liquid (condensate) collected in the pump head ?	Let the pump operate for a few minutes pumping air.
	Are the diaphragm or valve plates worn ?	Replace the diaphragm and valve plates (refer to Section 5.2.1).
Poor vacuum performance	Are the cross-section of pipelines or connected components too small or are they restricted ?	To check the performance, disconnect the pump from the system (small diameter tubing or a valve can significantly affect performance). Replace tubing or connected components as necessary.
	Is there a leak at a connector, in a pipeline or in the pump head ?	Seal any leaks found.
	Are the diaphragm or valve plates worn or is there dirt on the head ?	Refer to Section 5.2.1.
	After changing the diaphragm or valve plates has the head been reassembled in the wrong position ?	Reassemble the head correctly.

Table 4 - Fault finding

5.2.3 Spare parts and order numbers

Refer to Figure 5 to locate these items.

Item	Description
2	Intermediate plate
5	Cover plate
6	Valve plate
7	Sealing ring
8	Structured diaphragm
	Pneumatic connection

Table 5 - Spare parts

These parts are included in the diaphragm pump service kit (see Section 7.3).

5.3 AGC option (if fitted)

The AGC option contains a fuse. Isolate the unit from the electrical supply before removing covers.

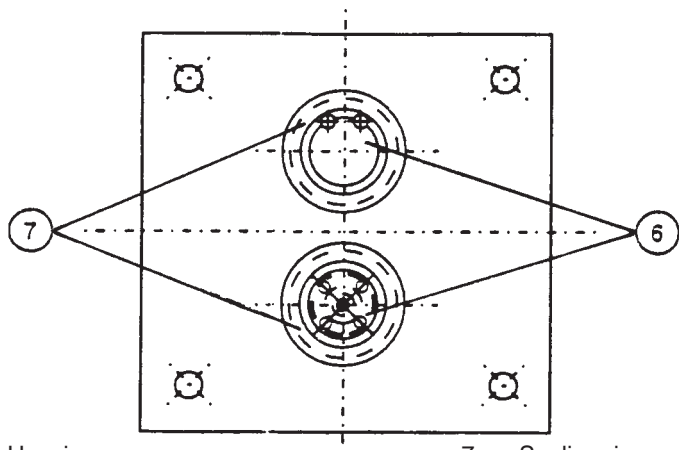
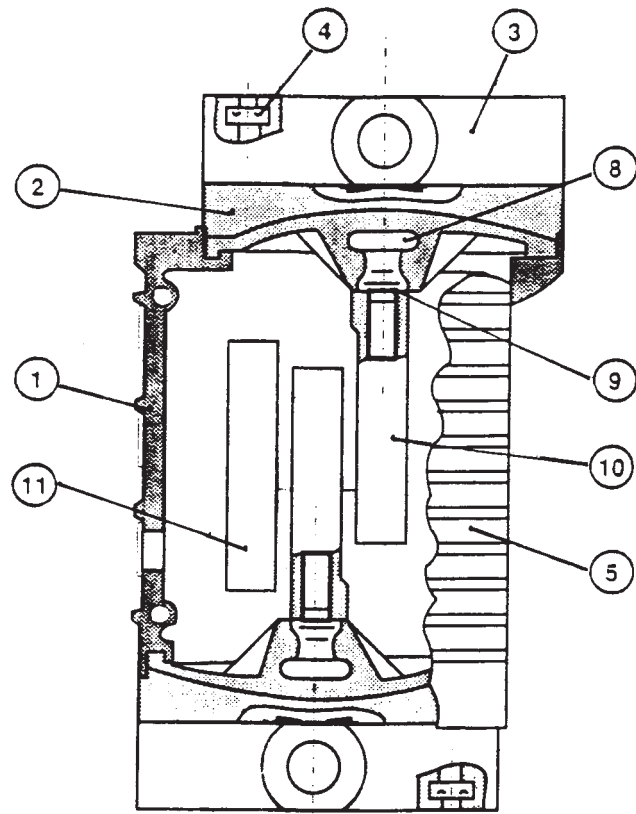

- | | |
|----------------------------------|-------------------------|
| 1. Housing | 7. Sealing ring |
| 2. Intermediate plate | 8. Structured diaphragm |
| 3. Ribbed plate | 9. Diaphragm spacer(s) |
| 4. Hexagon socket head cap screw | 10. Connecting rod |
| 5. Cover plate | 11. Counter weight |
| 6. Valve plate | |

Figure 5 - Components of the diaphragm pump

6 STORAGE AND DISPOSAL

6.1 Storage

Follow the procedure detailed below to store the PicoDRY unit:

1. Shut down the unit.
2. Isolate the unit from the electrical supply, and disconnect it from your vacuum system.
3. Place protective covers over the inlet and outlet.
4. Store the unit in cool dry conditions until it is required for use. When required, prepare and install the unit as described in Section 3.

6.2 Disposal

Dispose of the unit and any components removed from it in a safe manner in accordance with all local and national safety requirements.

7 SERVICE, SPARES AND ACCESSORIES

7.1 Introduction

BOC Edwards products, spares and accessories are available from BOC Edwards companies in Belgium, Brazil, China, France, Germany, Israel, Italy, Japan, Korea, Singapore, United Kingdom, U.S.A, and a world wide network of distributors. The majority of these centres employ Service Engineers who have undergone comprehensive BOC Edwards training courses.

Order spare parts and accessories from your nearest BOC Edwards company or distributor. When you order, please state for each part required:

- Model and Item Number of your equipment
- Serial number (if any)
- Item Number and description of part

7.2 Service

BOC Edwards products are supported by a world-wide network of BOC Edwards Service Centres. Each Service Centre offers a wide range of options including: equipment decontamination; service exchange; repair; rebuild and testing to factory specifications. Equipment which has been serviced, repaired or rebuilt is returned with a full warranty.

Your local Service Centre can also provide BOC Edwards engineers to support on-site maintenance, service or repair of your equipment.

For more information about service options, contact your nearest Service Centre or other BOC Edwards company.

7.3 Spares

AGC fuse rating	2 A, type T, slow-blow
Diaphragm pump service kit	

7.4 Accessories

Refer to the AGC instruction manual and EHVI catalogue for details of accessories.

8 ENGINEERING DIAGRAMS

Circuit diagram

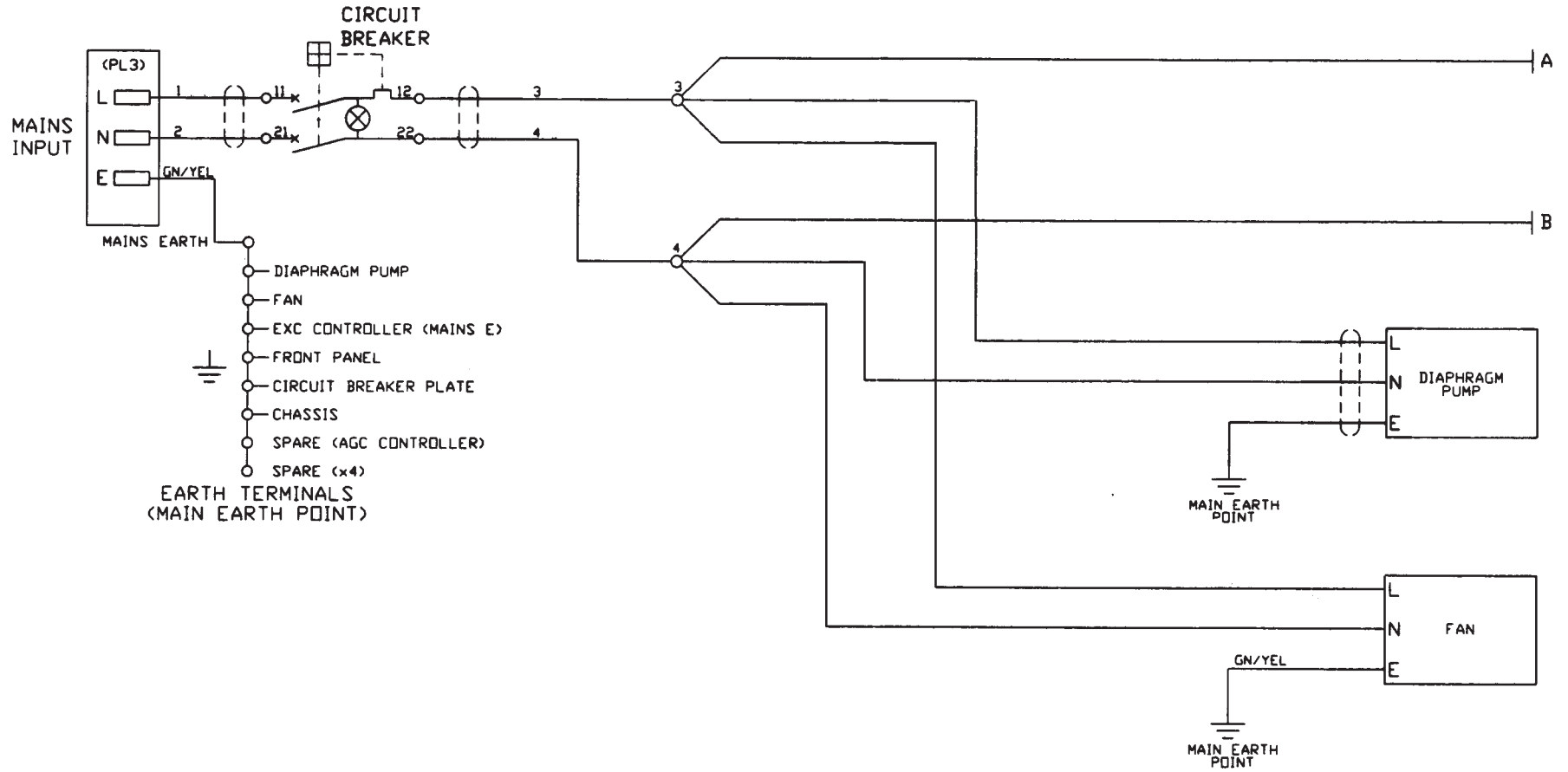

Figure 6 - Circuit diagram (sheet 1 of 2)

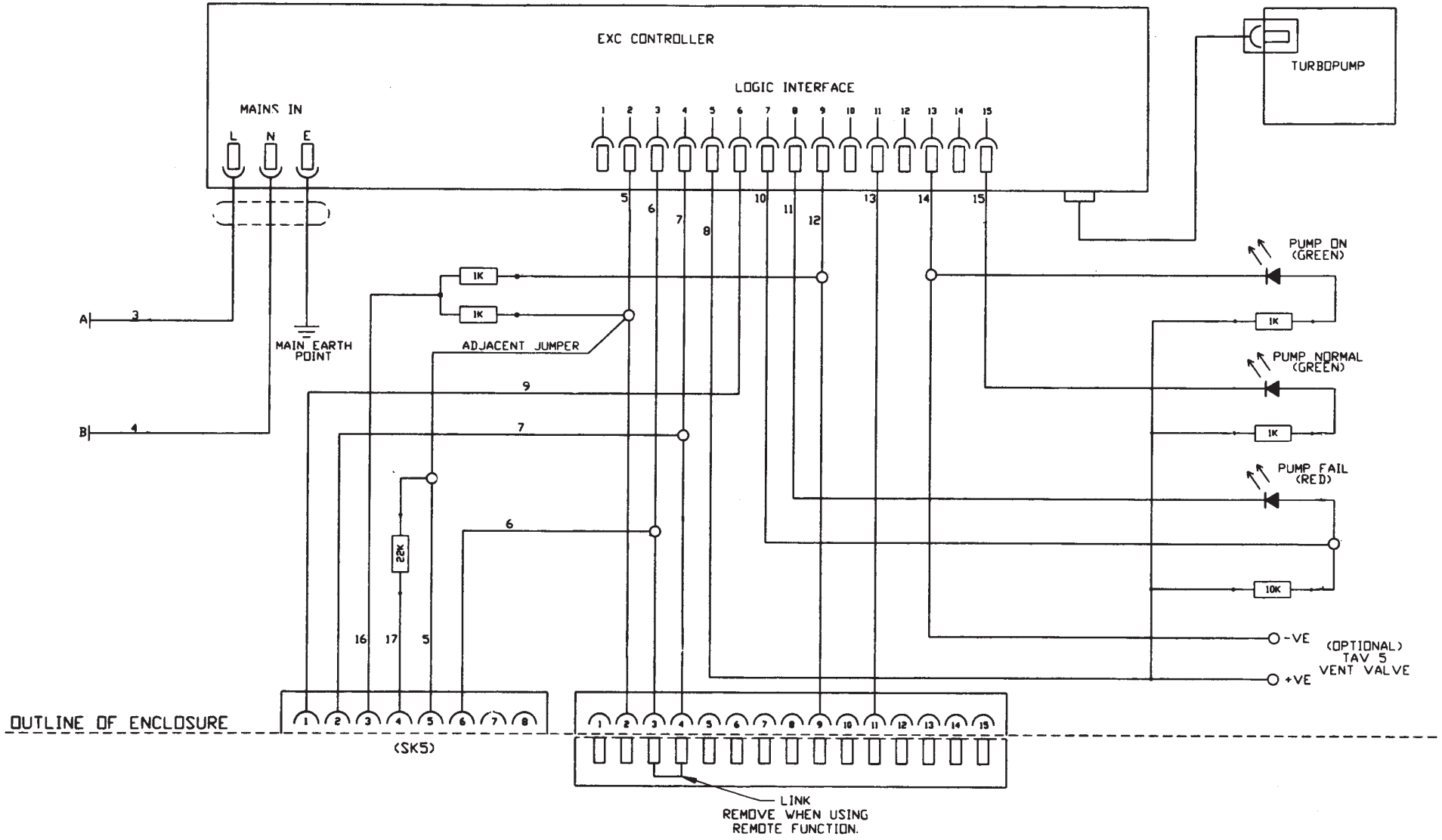

Figure 6 - Circuit diagram (sheet 2 of 2)

Return of BOC Edwards Equipment - Procedure (Form HS1)

Introduction

Before you return your equipment you must warn your supplier if the substances you used (and produced) in the equipment can be dangerous. You must do this to comply with health and safety at work laws.

You must complete the Declaration (HS2) on the next page and send it to your supplier before you dispatch the equipment. If you do not, your supplier will assume that the equipment is dangerous and he will refuse to accept it. If the Declaration is not completed correctly, there may be a delay in processing your equipment.

Guidelines

Take note of the following guidelines:

- Your equipment is '**uncontaminated**' if it has not been used or if it has only been used with substances that are not dangerous. Your equipment is '**contaminated**' if it has been used with any dangerous substances.
- If your equipment has been used with radioactive substances, you must decontaminate it before you return it to your supplier. You must send independent proof of decontamination (for example a certificate of analysis) to your supplier with the Declaration (HS2). Phone your supplier for advice.
- We recommend that contaminated equipment is transported in vehicles where the driver does not share the same air space as the equipment.

PROCEDURE

Use the following procedure:

1. Contact your supplier and obtain a Return Authorisation Number for your equipment.
2. Turn to the next page(s), photocopy and then complete the Declaration (HS2).
3. Remove all traces of dangerous gases: pass an inert gas through the equipment and any accessories which will be returned to your supplier. Drain all fluids and lubricants from the equipment and its accessories.
4. Disconnect all accessories from the equipment. Safely dispose of the filter elements from any oil mist filters.
5. Seal up all of the equipment's inlets and outlets (including those where accessories were attached). You may seal the inlets and outlets with blanking flanges or heavy gauge PVC tape.
6. Seal contaminated equipment in a thick polythene bag. If you do not have a polythene bag large enough to contain the equipment, you can use a thick polythene sheet.
7. If the equipment is large, strap the equipment and its accessories to a wooden pallet. Preferably, the pallet should be no larger than 510mm x 915mm (20" x 35"); contact your supplier if you cannot meet this requirement.
8. If the equipment is too small to be strapped to a pallet, pack it in a suitable strong box.
9. If the equipment is contaminated, label the pallet (or box) in accordance with laws covering the transport of dangerous substances.
10. Fax or post a copy of the Declaration (HS2) to your supplier. The Declaration must arrive before the equipment.
11. Give a copy of the Declaration to the carrier. You must tell the carrier if the equipment is contaminated.
12. Seal the original Declaration in a suitable envelope; attach the envelope securely to the outside of the equipment package. **WRITE YOUR RETURN AUTHORISATION NUMBER CLEARLY ON THE OUTSIDE OF THE ENVELOPE OR ON THE OUTSIDE OF THE EQUIPMENT PACKAGE.**

Return of BOC Edwards Equipment - Declaration (Form HS2)

Return Authorisation Number: _____

You must:

- Know about all of the substances which have been used and produced in the equipment before you complete this Declaration
- Read the Procedure (HS1) on the previous page before you attempt to complete this Declaration
- Contact your supplier to obtain a Return Authorisation Number and to obtain advice if you have any questions
- Send this form to your supplier before you return your equipment

SECTION 1 : EQUIPMENT

Equipment model _____

Serial Number _____

Has the equipment been used, tested or operated?

yes Go to Section 2 no Go to Section 4

FOR SEMICONDUCTOR APPLICATIONS ONLY :

Tool Reference Number _____

Process _____

Failure Date _____

Serial Number of Replacement Equipment _____

SECTION 2 : SUBSTANCES IN CONTACT WITH THE EQUIPMENT

Are any of the substances used or produced in the equipment

- Radioactive yes no
- Biologically active yes no
- Dangerous to human health and safety? yes no

If you have answered 'no' to all of these questions, go to Section 4.

Your supplier will not accept delivery of any equipment that is contaminated with radioactive substances, unless you:

- Decontaminate the equipment
- Provide proof of decontamination

YOU MUST CONTACT YOUR SUPPLIER FOR ADVICE BEFORE YOU RETURN SUCH EQUIPMENT

SECTION 3 : LIST OF SUBSTANCES IN CONTACT WITH THE EQUIPMENT

Substance name	Chemical symbol	Precautions required (for example, use protective gloves, etc.)	Action required after spillage or human contact
1			
2			
3			
4			
5			
6			

SECTION 4 : RETURN INFORMATION

Reason for return and symptoms of malfunction: _____

If you have a warranty claim:

- who did you buy the equipment from ? _____
- give the supplier's invoice number _____

SECTION 5 : DECLARATION

Print your name: _____ Print your job title: _____

Print your organisation: _____

Print your address: _____

Telephone number: _____ Date of equipment delivery: _____

I have made reasonable enquiry and I have supplied accurate information in this Declaration. I have not withheld any information. I have followed the Return of BOC Edwards Equipment Procedure (HS1) on the previous page.

Signed: _____ Date _____

Addresses

EUROPE

CORPORATE/EUROPE HEADQUARTERS

BOC Edwards
Manor Royal
Crowley
West Sussex, RH10 2LW
Tel: +(44) 1293 528844
Fax: +(44) 1293 533453

UNITED KINGDOM

(ENGLAND)
BOC Edwards
The Priestley Centre
10 Priestley Road
The Surrey Research Park
Guildford
Surrey, GU2 5XY
Tel: +(44) 1483 579857
Fax: +(44) 1483 505211

(SCOTLAND)

BOC Edwards
3 Deerdykes Road
Westfield
Cumbernauld
Strathclyde, G68 9HW
Tel: +(44) 1236 730575

BELGIUM

BOC Edwards
Bergensesteenweg 709
B1600 Sint-Pieters-Leeuw
Brussels
Tel: +(32) 2 363 00 30
Fax: +(32) 2 363 00 64

FRANCE

BOC Edwards
125 Avenue Louis Roche
92238 Gennevilliers cedex
Paris
Tel: +(33) 1 47 98 24 01
Fax: +(33) 1 47 98 44 54

GERMANY

BOC Edwards
Ammerthalstraße 36
85551 Kirchheim
Munich
Tel: +(49) 89 99 19 18 0
Fax: +(49) 89 99 19 18 99

ITALY

BOC Edwards
Via Carpaccio 35
20090 Trezzano sul Naviglio
Milan
Tel: +(39) 2 48 4471
Fax: +(39) 2 48 401638

ISRAEL

Edwards Israel Vacuum Ltd.
5 Habarzel Blvd
Gat 2000 Industrial Zone
Qiryat Gat 82000
Tel: +(972) 7 681 0633
Fax: +(972) 7 681 0640

ASIA

HEADQUARTERS

BOC Edwards (Asia)
2605 Shun Tak Centre, West Wing
200 Connaught Road Central
Hong Kong S.A.R.
Tel: +(852) 2796 9111
Fax: +(852) 2796 9095

CHINA

BOC Gases (Shanghai) Co. Ltd.
1525 Chuanqiao Road
Jinqiao, Pudong
Shanghai 201206
Tel: +(86) 21 5899 0272
Tianjin BOC Industrial Gases
Tel: +(86) 22 2834 1981

TAIWAN, R.O.C.

Edwards Taiwan Limited
No. 434 Chung-hua Road
Toufen Town, Miaoli County
Taiwan 351
Tel: +(886) (0)37 611422
Fax: +(886) (0)37 611401

SOUTH EAST ASIA

BOC Edwards
26 Changi South Street I
Changi South Industrial Estate
Singapore 486773
Tel: +(65) 546 8408
Fax: +(65) 546 8407

KOREA

HEADQUARTERS
Songwon Edwards Ltd
625-7 Upsong-dong
Chunan City
Chungchong Nam-do
Tel: +(82) 417 554 7070
Fax: +(82) 417 554 7300
(SEOUL)
Tel: +(82) 2 501 7070

AMERICAS

USA HEADQUARTERS

BOC Edwards
One Edwards Park
301 Ballardvale Street
Wilmington, MA 01887
Tel: +(1) 978 658 5410
Toll free (USA only): 800 848 9800
Fax: +(1) 978 658 7969

(ARIZONA)

BOC Edwards
Suite 101
1810 West Drake Drive
Tempe, AZ 85283
Tel: +(1) 602 777 7007
Fax: +(1) 602 777 2202

BOC Edwards
1810 West Drake Drive
Phoenix, AZ 85048
Tel: +(1) 602 777 7007
Fax: +(1) 602 777 2244

(CALIFORNIA)

BOC Edwards
3901 Burton Drive
Santa Clara, CA 95054
Tel: +(1) 408 496 1177
Fax: +(1) 408 496 1188

(TEXAS)

BOC Edwards
11701 Stone Hollow Drive
Austin, TX 78758
Tel: +(1) 512 491 6622
Fax: +(1) 512 389 3890

BOC Edwards
1343 Columbia Drive
Richardson, TX 75081
Tel: +(1) 972 669 9386
Fax: +(1) 972 669 8054

BRAZIL

BOC Do Brasil Ltda
Divisão Edwards Alto Vaco
Rua Bernardo Wrona 222
02710 São Paulo-SP
Tel: +(55) 11 8580377
Fax: +(55) 11 2652766

JAPAN

HEADQUARTERS
BOC Edwards
Shuwa Shiba Park Building A-3F
2-4-1 Shibakoen, Minato-ku
Tokyo, 105-0011
Tel: +(81) (0) 3 5470 6530
Fax: +(81) (0) 3 5470 6521

(Electronic Gases)
Osaka Sanso Kogyo KK
Tel: +(81) 3 3434 6789
Fax: +(81) 3 5472 8728

(OSAKA)

Esaka Yodo Building 5F
16-34, Enoki-cho
Suita-shi
Osaka 564-0053
Tel: +(81) (0) 6 6384 7052
Fax: +(81) (0) 6 6384 7504

(KYUSHU)

508-1, Yomogi-cho
Kumamoto-shi, 861-5515
Tel: +(81) (0) 96 326 7300
Fax: +(81) (0) 96 326 7302

(SENDAI)

1-37-1, Izumichuo
Izumi-ku
Sendai-shi, 981-3133
Tel: +(81) (0) 22 373 8525
Fax: +(81) (0) 22 373 9636



BOC Edwards is a trading name used by affiliate companies of The BOC Group plc. BOC Edwards and the stripe symbol are trademarks of The BOC Group plc.